

up by each gram of glass wool under like conditions. This points to a qualitative agreement in behavior of asbestos and glass wool.

### Summary.

The condensation of water from its saturated vapor in air on a steamed and water-washed glass surface and on an acid-washed, steamed and water-washed asbestos surface has been investigated under the conditions that have prevailed with many users of the gas-current saturation method of vapor pressure measurement. The amount of this condensation has been found to be sufficiently great to largely account for unexplained irregularities recorded in the literature of measurements by this method.

PRINCETON, N. J.

---

[CONTRIBUTION FROM THE DEPARTMENT OF CHEMISTRY OF CORNELL UNIVERSITY.]

## A SEARCH FOR AN ALKALI ELEMENT OF HIGHER ATOMIC WEIGHT THAN CESIUM.

By L. M. DENNIS AND R. W. G. WYCKOFF.

Received March 22, 1920.

As a result of his study of the X-ray spectra of the elements from aluminum to gold, Moseley<sup>1</sup> assigned atomic numbers to the elements, beginning with 13 for aluminum and closing with 79 for gold. He found known elements to correspond with all of these numbers except 3, and hence considered that there are probably 3 undiscovered elements between aluminum and gold. Siegbahn and Friman<sup>2</sup> extended the work of Moseley to the series of elements from tantalum to uranium, and found 3 unfilled places between polonium, atomic number 84, and radium, atomic number 88. The element with an atomic number of 87 would lie to the left of radium and would fall in Group 1 under cesium.

Search for this element, which may provisionally be termed eka-caesium, has already been made by Richards and Archibald,<sup>3</sup> and by Baxter.<sup>4</sup> Richards and Archibald subjected 150 g. of cesium dichloro-iodide to fractional crystallization with the object of concentrating eka-caesium, if it was present, in the fractions at one end of the series. Baxter fractionally crystallized a large amount of cesium nitrate. Neither investigation gave indication of the presence of a higher analogue of cesium.

It seemed desirable that further search for this eka-caesium be made, and that there be employed methods of fractionation involving the use of salts of cesium showing greater differences of solubility than do the

<sup>1</sup> *Phil. Mag.*, 27, 703 (1914).

<sup>2</sup> *Ibid.*, 32, 39 (1916).

<sup>3</sup> *Proc. Am. Acad.*, 38, 443 (1903).

<sup>4</sup> *THIS JOURNAL*, 37, 286 (1915).

dichloro-iodides or the nitrates. The solubilities of the nitrates of the alkalis are stated<sup>1</sup> to be as follows:

	Parts soluble in 100 parts water.	At.
KNO <sub>3</sub> .....	13.3	0°
RbNO <sub>3</sub> .....	20.1	0°
CsNO <sub>3</sub> .....	10.58	3°

If these values are correct, the nitrate of eka-caesium may be more soluble or less soluble than caesium nitrate; this uncertainty, together with the fact that the nitrates do not greatly differ in solubility, would render the search for the missing element more difficult than in the case of compounds of steadily progressing and markedly different solubility.

#### Experimental.

About 3500 g. of selected pollucite, containing over 30% of caesium oxide, was finely pulverized and was placed in large flasks that were fitted with reflux condensers. Conc. hydrochloric acid was added, and the contents of each flask was heated until decomposition of the mineral was complete, which required from 30 to 40 hours. The solution was diluted with water and was filtered. The filtrate was rendered slightly alkaline with ammonium hydroxide, and ammonium carbonate was added. The precipitate, which consisted chiefly of aluminum hydroxide and the carbonates of the alkaline earths, was removed by filtration, and to guard against possible loss of eka-caesium in this precipitate it was dissolved in sulfuric acid, and the alums which were thus formed were fractionated by evaporation of the solution to crystallization, discarding the mother liquor, dissolving the crystals in a small amount of hot water, cooling until crystals once more separated, and again discarding the mother liquor. This process was continued until the ammonium alum had been removed. The residual alums were later united with the alums from the sulfates, and were subjected to fractional solution, as will be described under D.

The filtrate from the precipitation of aluminum and the alkaline earths, which contained about 1250 g. of the alkalis as chlorides, was evaporated on the water bath to small bulk and the chlorides were then fractionally precipitated.

Throughout the whole investigation an arc-spectrum photograph was made of every fraction obtained by the various methods that are described below, and no material was in any case discarded until a photograph of its arc spectrum had carefully been studied.<sup>2</sup>

#### A. Fractional Precipitation of the Chlorides of the Alkalis.

The solubilities of the chlorides of the alkalis are stated<sup>3</sup> to be as follows:

<sup>1</sup> Comey, "Dictionary of Chemical Solubilities."

<sup>2</sup> The arc spectra disclosed the presence in the mineral of an appreciable amount of vanadium.

<sup>3</sup> Comey, *ibid.*

	Parts in 100 parts of water.	At.
LiCl.....	63.7	0°
NaCl.....	35.7	0°
KCl.....	28.5	0°
RbCl.....	76.28	1°
CsCl.....	Very deliquescent.	

These data indicate that eka-caesium chloride would be more soluble in water than any other of the alkali chlorides, and that it would be concentrated in the more soluble portions if the alkali chlorides were subjected to systematic fractional precipitation. To this end, hydrogen chloride was passed into the saturated solution of the chlorides (No. 1 in the scheme shown in Fig. 1) until about 20 g. of the chlorides was precipitated. These crystals (2) were removed by filtration and were then dissolved in a little

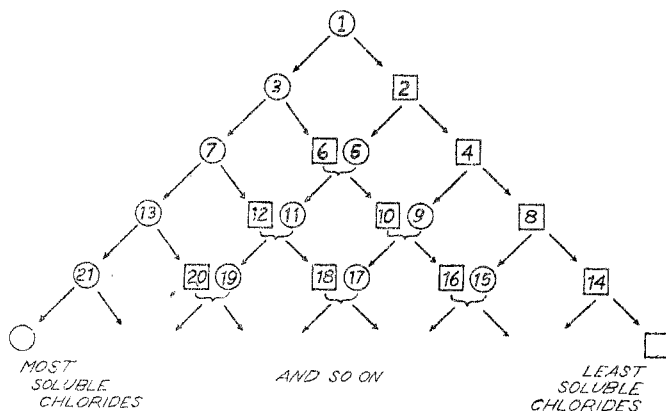

Fig. 1.

water and again precipitated by hydrogen chloride, yielding crystals (4) and mother liquor (5). The filtrate (3) from the first crop of crystals was treated with hydrogen chloride until a further precipitate (6) of about 20 g. of the chlorides resulted. Filtration yielded precipitate (6) and mother liquor (7). Precipitate (4) was dissolved in a little water and again precipitated. (5) and (6) were combined and precipitated. The fractionation was continued until 100 cc. of a saturated solution of the most soluble chlorides remained.

As the fractionation proceeded, it became necessary to concentrate the solutions. Bailey has stated<sup>1</sup> that when a solution of one of the alkali chlorides is boiled, a small amount of the salt passes off. The loss in the case of cesium chloride was said to be greater than with potassium chloride. Washburn and Millard, on the other hand, found that there was no loss of cesium chloride when its aqueous solution was subjected to prolonged boiling.<sup>2</sup> To avoid any possibility of the loss of eka-caesium, however,

<sup>1</sup> *J. Chem. Soc.*, 65, 445 (1894).

<sup>2</sup> *THIS JOURNAL*, 37, 694 (1915).

the concentration of the solutions during the fractionation was carried on under diminished pressure and the distillates were collected in flasks that contained cold water.

This fractional precipitation of the chlorides did not yield complete separation even of lithium from cesium, for the spectrum photograph of the final, most soluble portion showed that lithium was present.

Yet eka-caesium might be expected to be concentrated in this most soluble portion, and consequently this material was converted to perchlorates and was treated as described under B.

### B. Fractional Solution of the Perchlorates of the Alkalies.

The saturated solution of the most soluble chlorides, mentioned in the preceding paragraph, amounted to about 100 cc. Perchloric acid was added in slight excess to  $\frac{1}{2}$  this solution and the resulting precipitate of the alkali perchlorates was then subjected to fractional solution, first with portions of cold water and later with portions of hot water. About 300 cc. of water was used in each fractional treatment and the precipitate and the water was in each case thoroughly stirred by a current of air. The solution was then decanted from the precipitate and the residue was again treated with water.

This fractional solution of the perchlorates was continued until the residual, least soluble, portion had been reduced to about 10 g. Arc-spectrum photographs of this residue in the red, the visible, and the ultra-violet fields showed the presence of cesium only.

### C. Fractional Crystallization of the Sulfates of the Alkalies.

The solubilities of the sulfates of the alkali metals are stated<sup>1</sup> to be:

	Parts in 100 parts water.	At.
$\text{Li}_2\text{SO}_4$ .....	35.34	0°
$\text{Na}_2\text{SO}_4$ .....	50.2	0°; 48 parts $\text{Na}_2\text{SO}_4 \cdot 10\text{H}_2\text{O}$ at 18°
$\text{Tl}_2\text{SO}_4$ .....	21.1	15°; less at higher temp.
$(\text{NH}_4)_2\text{SO}_4$ .....	70.0	0°
$\text{K}_2\text{SO}_4$ .....	8.5	0°
$\text{Rb}_2\text{SO}_4$ .....	42.4	10°
$\text{Cs}_2\text{SO}_4$ .....	158.7	-2°

These data would lead one to expect that if the sulfates were fractionally crystallized, the sulfate of eka-caesium would be concentrated in the most soluble portion.

All of the material containing the alkalies that had been extracted from the pollucite, with the exception of the small amount of alums mentioned on page 986 and the small amount of the chlorides used for the perchlorate fractionation were united. A small portion of this material containing the alkalies chiefly as chlorides was heated with conc. sulfuric

<sup>1</sup> Comey, *ibid.*

acid under reduced pressure in a closed apparatus, and the hydrogen chloride that was evolved was absorbed in water. This solution was examined for the presence of metallic chlorides to ascertain whether any cesium chloride (or eka-cesium chloride) passed off with the hydrogen chloride. No metallic chlorides were found in this solution and consequently all of the material was then converted to chlorides by adding conc. sulfuric acid to it and heating the solution until the hydrogen chloride was expelled. The sulfates in this resulting solution were then fractionally separated by crystallization by successive concentrations of the solution. Thallium sulfate appeared first in the least soluble fraction, together with small amounts of the sulfates of potassium, sodium, and rubidium, these being followed by large amounts of ammonium sulfate. This fractionation was continued until about 200 cc. of a saturated solution of the sulfates remained. The arc-spectrum photograph of the salt in this solution showed that only cesium was present.

#### D. Fractional Solution of the Alums of the Alkali Metals.

The solubilities of the aluminum alums of potassium, ammonium, rubidium and cesium are stated<sup>1</sup> to be as follows:

	Parts in 100 parts water.	At.
Potassium alun.....	13.5	17°
Ammonium " .....	8.74	17.5°
Rubidium " .....	2.27	17°
Cesium " .....	0.619	17°

It is clear from this tabulation that the alum of eka-cesium would be less soluble than that of cesium and would probably be but very sparingly soluble in water. The solution of the last fraction of the sulfates from C was diluted and a saturated solution of aluminum sulfate was added in slight excess. This caused immediate precipitation of the alums in bulky form. The total weight of this precipitate was more than 1000 g. These alums were then fractionally dissolved by heating the precipitate with successive portions of water and vigorously stirring the solution and precipitate together while the liquid was cooling. This stirring was necessary to destroy the supersaturated solutions that these alums, particularly cesium alum, readily tend to form. One liter of water was used in the first extractions and as the amount of the residual alums gradually decreased the portions of water for the successive treatment were lessened until toward the end 100 cc. was used. After each fractional solution the cold mother liquor was poured off and the residual alums were treated with a new portion of water. The arc-spectrum photographs of the final residue showed only cesium to be present.

#### Summary.

The alkalis from 3500 g. of pollucite were subjected to fractionation:

A. By precipitation of the chlorides with hydrogen chloride.

<sup>1</sup> *Comey, ibid.*

- B. By solution of the perchlorates.  
 C. By crystallization of the sulfates.  
 D. By solution of the alums.

In these several processes those fractions in which the higher analogue of cesium, eka-cesium, might be expected to be concentrated were examined by means of the arc spectra of the solid material in the red, the visible, and the ultra-violet portions of the spectrum. In no case were there indications of the existence of eka-cesium.

ITHACA, N. Y.

---

### NOTE.

**Correction.**—Dr. F. H. MacDougall has kindly called my attention to the fact that several errors occur in the article entitled *The Form of the Conductance Function in Dilute Solutions*, which appeared in the January, 1920, number of *THIS JOURNAL*.

Equation VII should have been written in the general form

$$\frac{d\Lambda}{d(C\Lambda)} = \frac{C\Lambda}{K'^2} \frac{dK'}{d(C\Lambda)} - \frac{1}{K'}$$

Equation VII is in general a limiting form of this equation, which is approached as the concentration decreases. As long as  $\frac{dK'}{d(C\Lambda)}$  remains finite, it follows that the first term of the right-hand member will disappear at the concentration  $C = 0$ . In case, however, that  $\frac{dK'}{d(C\Lambda)}$  approaches infinity as the concentration approaches zero, the expression becomes indeterminate. In general, however, we may expect that this term will approach zero in the limit. If the value of  $\frac{dK'}{d(C\Lambda)}$  be substituted from Equation XV we obtain the expression

$$\frac{d\Lambda}{d(C\Lambda)} = \frac{Dm(C\Lambda)^m}{K'^2\Lambda_0^m} - \frac{1}{K'}$$

from which it follows that even though  $\frac{dK'}{d(C\Lambda)}$  becomes infinite as the concentration approaches the value zero, the term as a whole approaches the value zero and  $\frac{d\Lambda}{d(C\Lambda)}$  approaches the value  $-\frac{1}{K'}$ . Equation VIII was intended to be written in the form

$$\frac{d^2\Lambda}{d(C\Lambda)^2} = \frac{dK'/d(C\Lambda)}{K'^2}$$

but it is very doubtful whether this relation would be approximated even